



## FEATURES

- Accuracy  $\pm 0.2\%$  R.O.
- Watt, Var packaged in one case
- Precision measurement even for unbalance system
- Precision measurement even for distorted wave
- High impulse & surge protection (5KV)
- The case can be mounted on a 35mm rail which complies with DIN 46277



## DESCRIPTION

**Model:** S3-WRD-1 1 $\Phi$ 2W, WATT/VAR  
 S3-WRD-3 3 $\Phi$ 3W, WATT/VAR  
 S3-WRD-3A 3 $\Phi$ 4W, WATT/VAR

A wide range of transducers to measure all forms of watt, var, in both balanced and unbalanced, single or 3 phase system. They utilize the well prove "time division multiplication" method of measuring instantaneous power over a wide range of input waveforms. The circuit diagram shown measured voltage is modulated by circuit of an oscillator. Square wave pulses from a multi-vibrator circuit, with a mark-space ratio varied by the measured voltage and amplitude by the measured current, are fed to an integrator an output amplification circuit. The dc signal produced is then directly proportional to power input - watt & Vars.

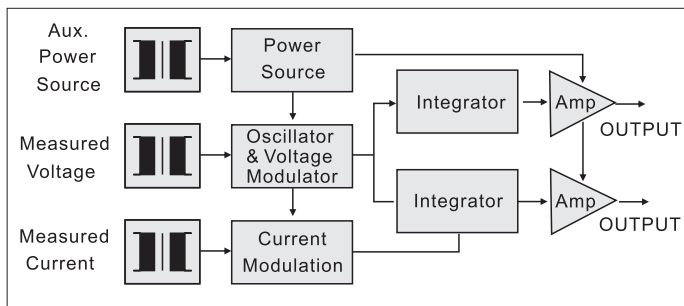

## INPUT - OUTPUT CURVE

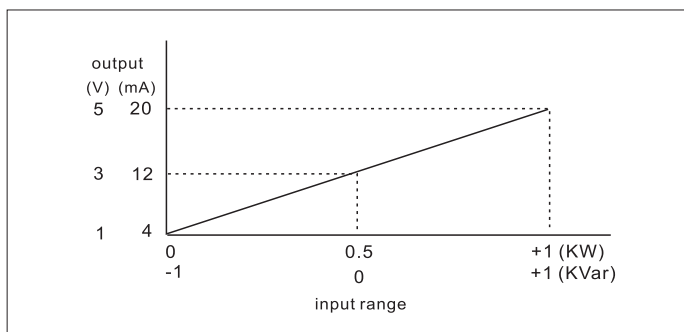

## SPECIFICATION

### INPUT

Circuit	Input Range				Max. Input Over Capability
	Amp.	Voltage	Basic Watt	Basic Var	
Single Phase	5A	110V (120V)	0.5 KW	$\pm 0.5$ KVar	Ampere: 3 x rated continuous 10 x rated 10 sec. 50 x rated 1 sec.  Voltage: 2 x rated continuous
		220V (240V)	1 KW	$\pm 1$ KVar	
3-Phase 3-Wire	5A	110V (120V)	1 KW	$\pm 1$ KVar	
		220V (240V)	2 KW	$\pm 2$ KVar	
3-Phase 4-Wire	5A	190V/110V (208/120V)	1.5 KW	$\pm 1.5$ KVar	
		380V/220V (416/240V)	3 KW	$\pm 3$ KVar	

### OUTPUT

DC Output Range	Load Resistance	Output Resistance	Output Ripple	Response Time
0 ~ 1V	$\cong 1$ K $\Omega$	$\cong 0.05\Omega$	$\cong 0.5\%$ R.O. (peak)	$\cong 400$ ms. 0 ~ 99%
0 ~ 5V				
1 ~ 5V				
0 ~ 10V	$\cong 10$ K $\Omega$	$\cong 20$ M $\Omega$		
0 ~ 1mA				
0 ~ 10mA	$\cong 1$ k $\Omega$	$\cong 5$ M $\Omega$		
0 ~ 20mA	$\cong 500\Omega$			
4 ~ 20mA				

- Accuracy  $\pm 0.2\%$  Rated of Output
- Input frequency 50HZ  $\pm 3$ HZ or 60HZ  $\pm 3$ HZ
- Input burden  $\cong 0.1$ VA (ampere input)  
 $\cong 0.2$ VA (voltage input)
- Aux. power source AC 110 V  $\pm 15\%$ , 50/60HZ  
AC 220 V  $\pm 15\%$ , 50/60HZ  
DC 24V, 48V, 110V  $\pm 10\%$
- Power effect  $\cong 0.1\%$  R.O.
- Power consumption AC  $\cong 9$ VA, DC  $\cong 7$ W
- Waveform effect  $\cong 0.2\%$  R.O. at distortion factor 15%
- Output load effect  $\cong 0.05\%$  R.O.
- Electromagnetic balance effect  $\cong 0.1\%$  R.O.
- Mutual interference effect  $\cong 0.1\%$  R.O. between element
- Magnetic field strength  $\cong 0.2\%$  R.O. 400A/M
- Span adjustment range  $\cong 5\%$  R.O.
- Zero adjustment range  $\cong 1\%$  R.O.
- Operating temperature range 0 ~ 60  $^{\circ}$ C
- Storage temperature range -10 ~ 70  $^{\circ}$ C
- Temperature coefficient  $\cong 100$ PPM from 0 ~ 60  $^{\circ}$ C  
60PPM, 25  $^{\circ}$ C  $\pm 10$   $^{\circ}$ C
- Max. relative humidity 95%
- Isolation Input/output/power/case
- Dielectric withstand resistance  $\cong 100$ M $\Omega$ , DC 500 V
- Dielectric withstand voltage Between input/output/power/case  
IEC 60688 AC 2.6 KV, 60 HZ, 1 minute
- Impulse withstand test 5KV, 1.2 x 50  $\mu$ s  
IEC 61000-4-5 Common mode & differential mode
- Performance Designed to comply with IEC 60688



## ORDER INFORMATION

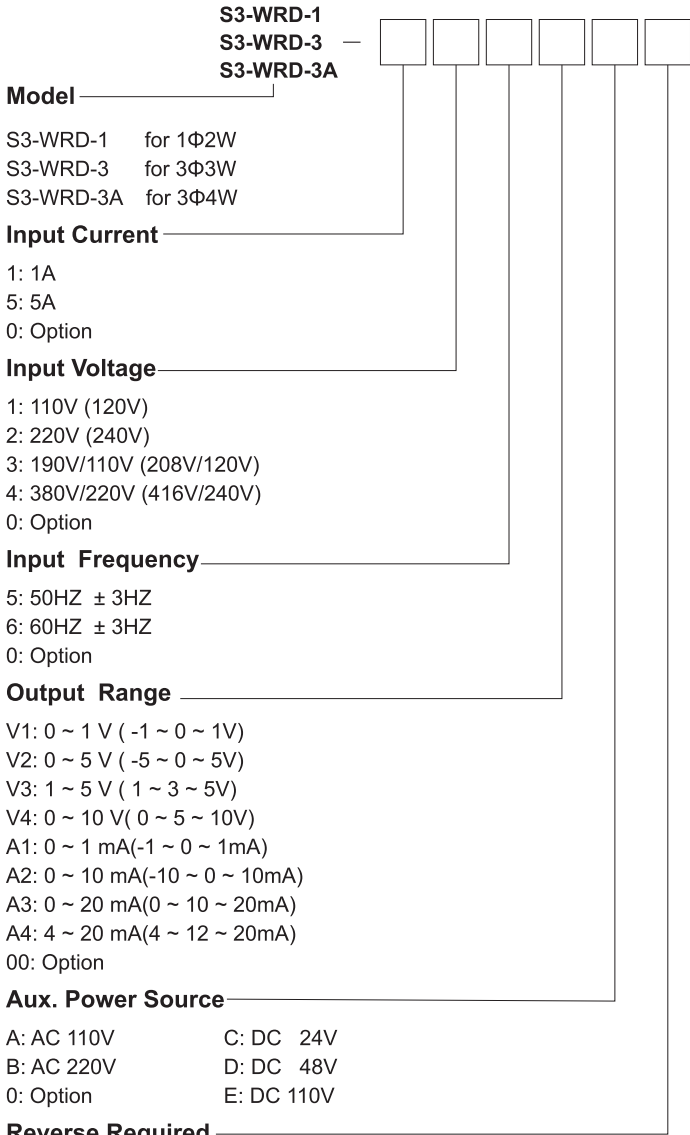

\*Remark: The value in parentheses is VAR output or Reverse Watt output

## THE OUTSIDE DIMENSION (UNIT:mm)

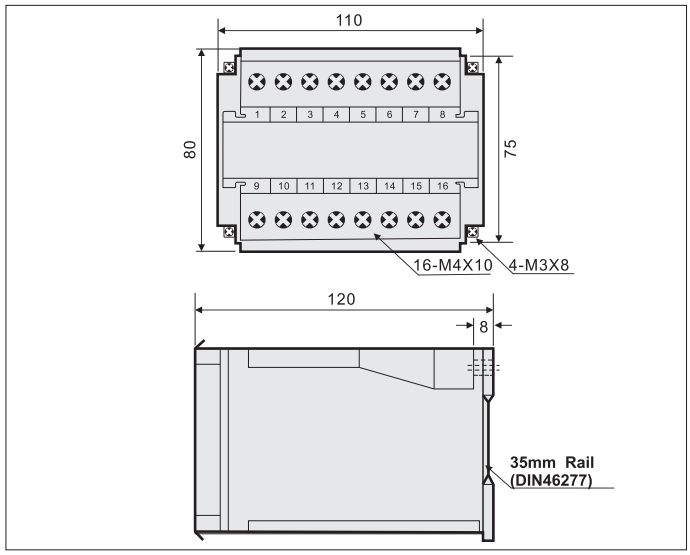

## • PANEL MOUNTING HOLES (UNIT:mm)

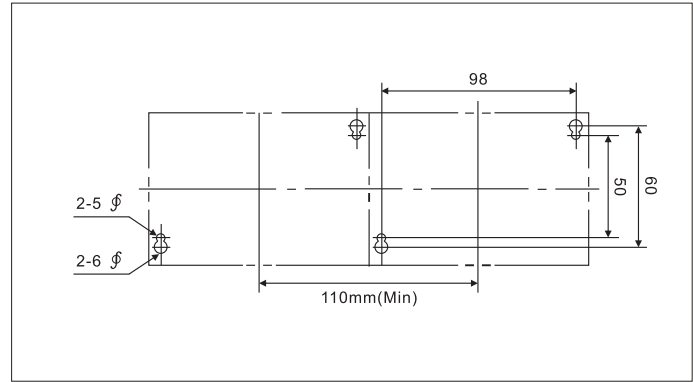

## CONNECTION DIAGRAM

### S3-WRD-1 (1Φ2W)

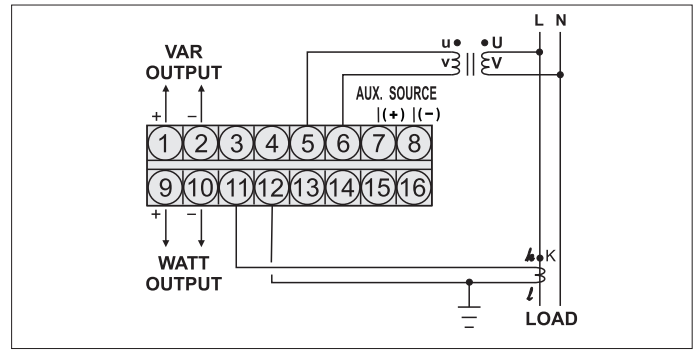

### S3-WRD-3 (3Φ3W)

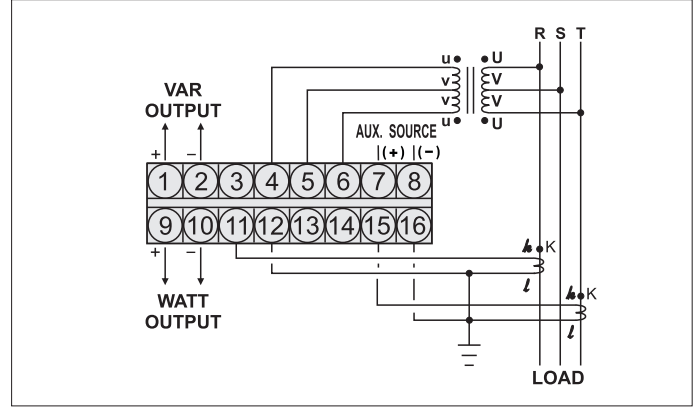

### S3-WRD-3A (3Φ4W)

