



# AC VOLTAGE TRANSDUCER

**S3-VD**  
SERIES

## FEATURES

- Accuracy  $\pm 0.2\%$  R.O.
- Excellent long term stability (4 ~ 20mA, 500 $\Omega$ )
- Precision measurement even for distorted wave (S3-VD-1T)
- High impulse & surge protection (5KV)
- The case can be mounted on a 35mm rail which complies with DIN 46277



## DESCRIPTION

**Model:** S3-VD-1 1 $\Phi$  input (AVG.)  
 S3-VD-3 3 $\Phi$  input (AVG.)  
 S3-VD-1T 1 $\Phi$  input (TRMS)

### Sinusoidal Waveforms - AVG.

S3-VD Series Transducer converting a sinusoidal alternating voltage into a dc output, proportional to the RMS value of input. These units are average sensing, but RMS calibrated for a sine wave with less than 1% distortion. The input signal is converted to a dc voltage which then feeds to a single stage amplifier and a dc output produced.

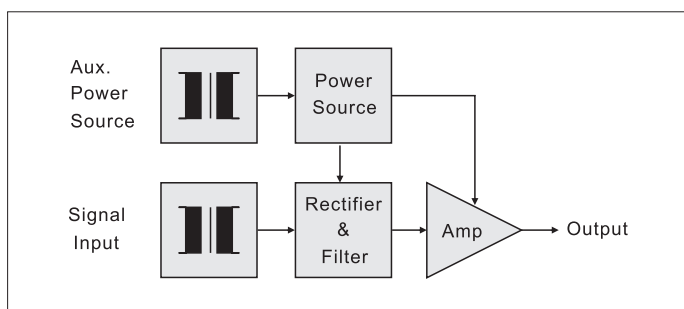

### Non-Sinusoidal Waveforms - TRMS

S3-VD-1T Transducer are designed for use on waveforms with up to 30% of 3rd harmonic content. The input signal is fed to an RMS detection circuit and the resultant dc volts produced are a linear function of the RMS value of input waveform. This dc voltage is converted to a milliamp output via an output amplification circuit.

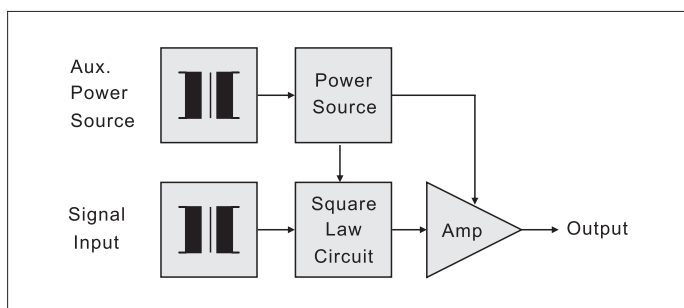

## INPUT-OUTPUT CURVE

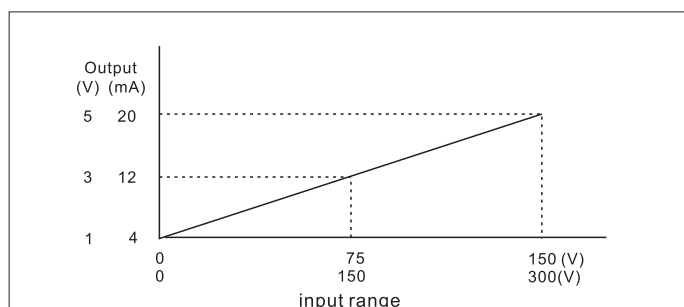

## SPECIFICATION

### INPUT

Input Range	Input Burden	Input Frequency	Max. Input Over capability
0 ~ 150V	$\cong 0.2VA$	50Hz $\pm$ 3Hz	2 x rated continuous
0 ~ 300V		or 60Hz $\pm$ 3Hz	

### OUTPUT

DC Output Range	Load Resistance	Output Resistance	Output Ripple	Response Time
0 ~ 1V	$\cong 1 K\Omega$	$\cong 0.05\Omega$	$\cong 0.5\%$ R.O. peak	$\cong 400mS$ 0 ~ 99%
0 ~ 5V				
1 ~ 5V				
0 ~ 10V	$\cong 20M\Omega$			
0 ~ 1mA				
0 ~ 10mA				
0 ~ 20mA				
4 ~ 20mA	$\cong 500\Omega$	$\cong 5M\Omega$		

Accuracy.....  $\pm 0.2\%$  Rated of Output  
 Aux. power source..... AC 110V  $\pm 15\%$ , 50/60HZ  
 AC 220V  $\pm 15\%$ , 50/60HZ  
 DC24V, 48V, 110V,  $\pm 10\%$   
 Power consumption ..... AC  $\cong 2.5VA$ , DC  $\cong 3W$   
 Power effect .....  $\cong 0.1\%$  R.O.  
 Waveform effect .....  $\cong 0.2\%$  R.O. at distortion factor 30%  
 (S3-VD-1T)  
 Output load effect .....  $\cong 0.05\%$  R.O.  
 Magnetic field strength .....  $\cong 0.2\%$  R.O., 400A/M  
 Span adjustment range .....  $\cong 5\%$  R.O.  
 Zero adjustment range.....  $\cong 1\%$  R.O.  
 Operating temperature range ..... 0 ~ 60  $^{\circ}C$   
 Storage temperature range ..... -10 ~ 70  $^{\circ}C$   
 Temperature coefficient .....  $\cong 100PPM$  from 0 to 60  $^{\circ}C$   
 $\cong 60PPM$  25  $^{\circ}C$   $\pm 10$   $^{\circ}C$   
 Max. relative humidity..... 95%  
 Isolation ..... Input/output/power/case  
 Insulation resistance.....  $\cong 100M\Omega$ , DC 500V  
 Dielectric withstand voltage..... Between input/output/power/case  
 IEC 60688  
 AC 2.6KV, 60HZ, 1 minute  
 Impulse withstand test..... 5KV, 1.2 X 50 $\mu S$   
 IEC 61000-4-5  
 Common mode & differential mode  
 Performance..... Designed to comply with IEC 60688



# AC VOLTAGE TRANSDUCER

**S3-VD**  
SERIES

## ORDERING INFORMATION

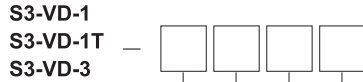

### Model

- S3-VD-1 for 1Φ input (AVG.)
- S3-VD-3 for 3Φ input (AVG.)
- S3-VD-1T for 3Φ input (TRMS)

### Input Range

- 1: 0 ~ 150V
- 3: 0 ~ 300V
- 0: Option

### Input Frequency

- 5: 50HZ ± 3HZ
- 6: 60HZ ± 3HZ
- 0: Option

### Output Range

- V1: 0 ~ 1V      A1: 0 ~ 1mA
- V2: 0 ~ 5V      A2: 0 ~ 10mA
- V3: 1 ~ 5V      A3: 0 ~ 20mA
- V4: 0 ~ 10V     A4: 4 ~ 20mA
- 00: Option

### Aux. Power Source

- A: AC 110V      C: DC 24V
- B: AC 220V     D: DC 48V
- 0: Option        E: DC 110V

### EXAMPLE

Input: 1ΦAC 0 ~ 150V, 60HZ, Output: DC 4-20mA  
 Aux. Power source: AC 110V  
 Ordering model: S3-VD-1-16A4A

## CONNECTION DIAGRAM

### • S3-VD-1, S3-VD-1T

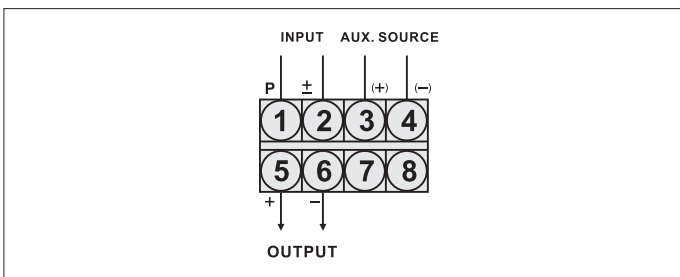

### • S3-VD-3

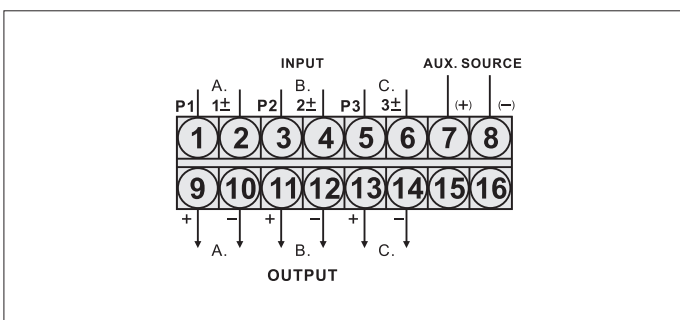

## THE OUTSIDE DIMENSION (UNIT: mm)

### • S3-VD-1, S3-VD-1T

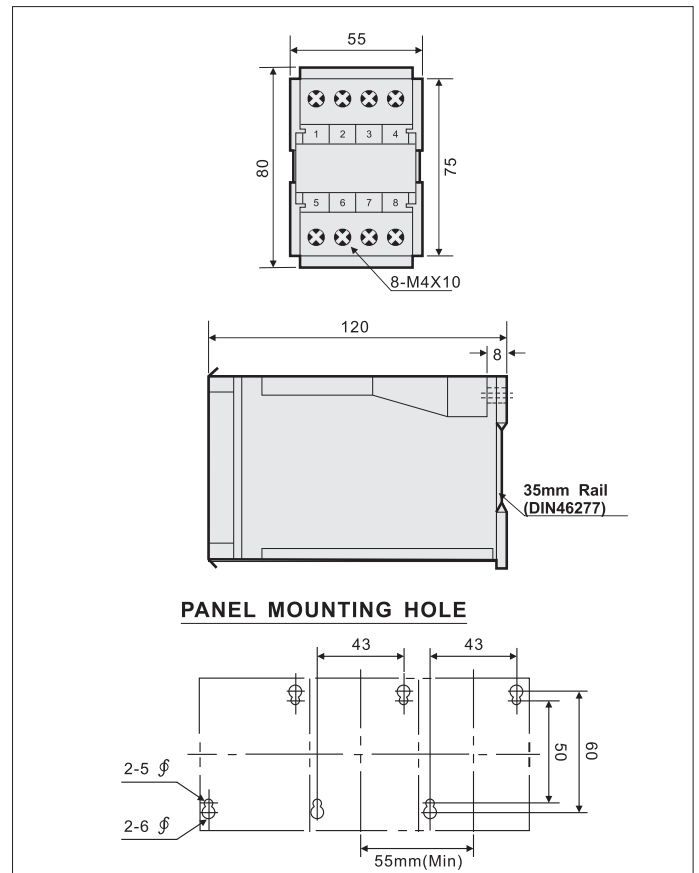

### • S3-VD-3

