

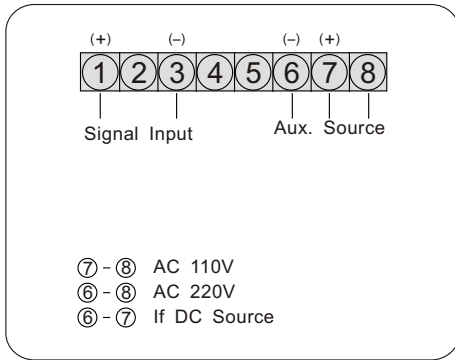

## CONNECTION DIAGRAMS

Figure A.



## OUTSIDE DIMENSION (UNIT:mm)

Figure 01.

● PANEL CUT-OUT

