

CONNECTION DIAGRAMS

Figure B.

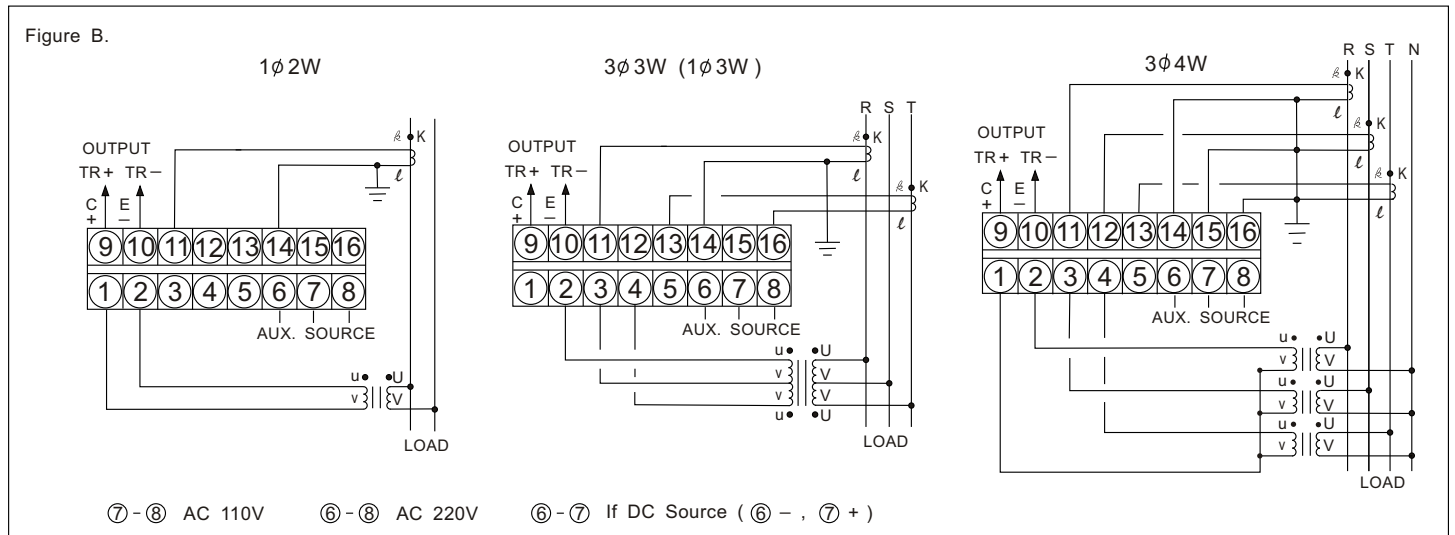

DIMENSIONS (Measurements in mm)

Figure 02.

● PANEL CUT-OUT

